

LCD-CM2

dual LCD monitor ceiling mount

Product Features:

- adapts an LCD-1C to accommodate two LCD monitors
- holds most 10" - 23" LCD monitors
- accommodates monitors with 75 or 100mm VESA standards
- has adjustable -5° to +30° tilt and rotates 240° at monitor
- LCD-CM2 and LCD-1C combined load capacity 50 lbs

Product Specifications: *(for Architects & Engineers)*

The adaptor which will allow two ceiling mounted LCD displays shall be the Video Mount Products (VMP) model LCD-CM2. The adaptor shall be used with one LCD-1C to mount LCD displays to the ceiling or other suitable support surface. The adaptor shall be constructed primarily of formed steel and shall incorporate nylon filled nuts and arc welds. The load capacity of the combined LCD-CM2 and LCD-1C shall be 50 lbs.

Video Mount Products
325 Log Canoe Circle
Stevensville, MD 21666
Phone: 410.643.6390
Fax: 410.643.6615
www.videomount.com



* LCD-CM2 shown assembled with LCD-1C (not included)

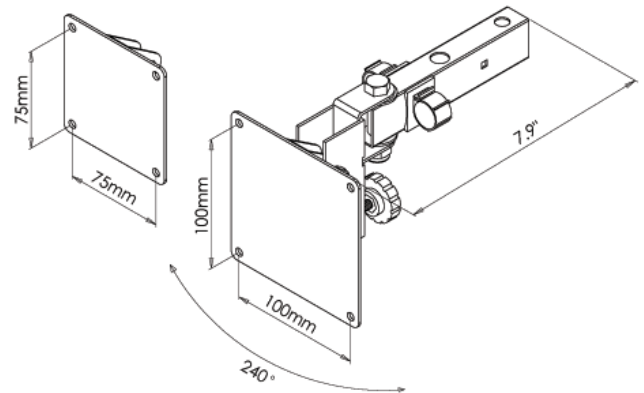

VMP
VIDEO MOUNT PRODUCTS